

# THE HARTFORD SERIES



BEAUTIFULLY  
DESIGNED  
WITH YOU  
IN MIND

*Every time you look through a double-hung and double-slider vinyl window, the world comes to life. Our windows are uniquely designed to fit the way you live, blending advanced technology with innovative features that add beauty and value to your home.*

# Heartland

WINDOWS

# “The Strength of the Heartland”

*The performance and durability of our vinyl replacement windows is determined by the character of the vinyl itself. We follow the most demanding manufacturing standards to ensure the quality of every vinyl component we produce.*

## CLEAN WITH EASE FROM THE INSIDE OUT

The tilt-in sashes on our double-hung and double-slider make cleaning from indoors a snap.

## THE STRONGEST VINYL FRAMES

Fusion-welded corners and a multiple hollow chamber design build strength and structural integrity directly into every vinyl window we manufacture.

## PUT AWAY THE PAINT FOR GOOD

Integral color throughout the vinyl creates a lasting finish that never needs painting. The vinyl in our windows will never chip, peel, or crack—guaranteed!

## ENERGY-EFFICIENT

Our multiple hollow chamber design produces a thermally efficient frame with superior resistance to heat transfer.

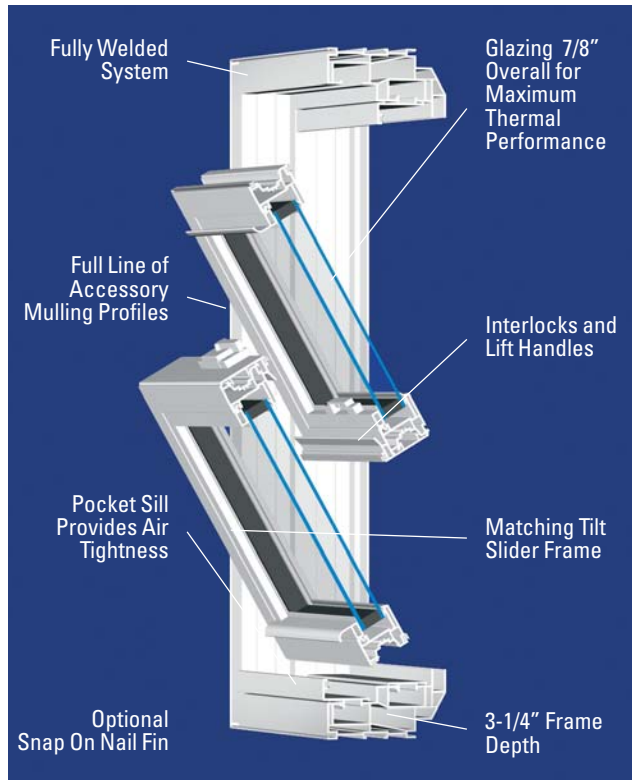

## FEEL SAFE AND SECURE

Our dual positive-action cam locks ensures a weather-tight seal and added security.

## INSTALLATION MADE EASY

Our windows are designed for easy installation. Each window is custom-made to your exact window openings, eliminating extensive renovating costs.

## STAY PROTECTED FROM WIND AND WATER

Interlocking sashes on our windows provide maximum protection from wind and water penetration.

## 700 SERIES WINDOWS

Available in double-hung and double-slider window styles.

## LOW E = HIGH PERFORMANCE

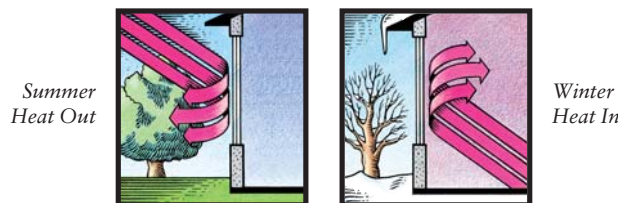

Low E (low emissivity) coated glass is an important component of all our windows and doors. Low E specifies a microscopically thin, virtually invisible coating deposited on a glass surface. This coating limits radiant heat flow between window panes by reflecting heat into your home during cold weather, and back to the outdoors during warm weather.

Your authorized Window dealer:

name  
address1  
address2  
csz  
phone

